

THREE-WAY BUTT WELD END BALL VALVE

with two seats, with full bore "L" or "T"

KM 9303.X-01

DN 10–50 PN 16, 25, 40, 63, 100 (160, 250)

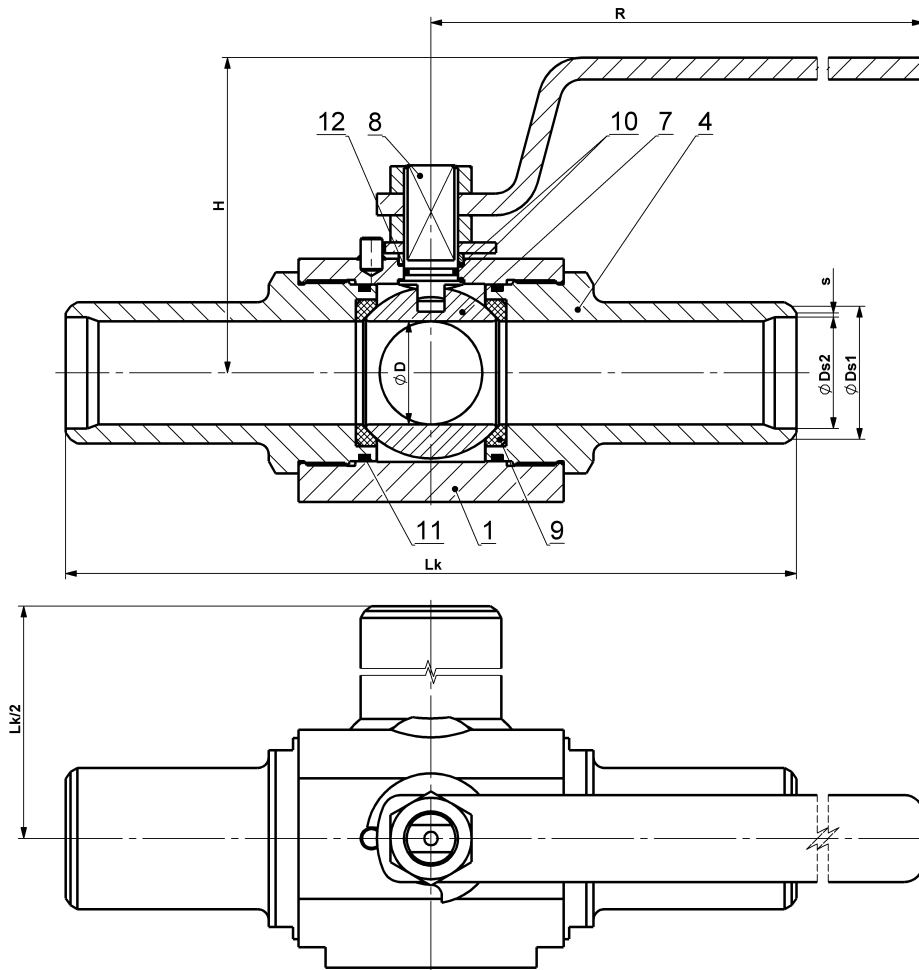

Materials

Type KM 9303.X-01		Material			
		Carbon steel		Stainless steel	
Position	Component	X=1 For common temperatures from -20°C to +200°C	X=5 For low temperatures from -46°C to +200°C	X=3 For temperatures from -50°C to +200°C	X=4 For temperatures from -50°C to +200°C
1	Body	1.0577, S355J2	1.0565, A350 LF2	1.4541, A182 F321	1.4571, A182 F316
2	Socket				
7	Ball	1.4021, ČSN 17 027	1.4541, A182 F321 ČSN 17 027	1.4541, A182 F321	1.4571, A182 F316
8	Stem				
9	Seat	PTFE, PTFE+C, PEEK			
10	Gasket	PTFE+C, PEEK			
11	Sealing	NBR, HNBR, EPDM, FPM, FPM+FEP			
12	Sealing	NBR, HNBR, EPDM, FPM, FPM+FEP			

Other materials upon request (P265GH, 1.4306, 1.4462 etc.).

Operating temperature range can be reduced based on selected sealing materials.

THREE-WAY BUTT WELD END BALL VALVE

with two seats, with full bore “L” or “T”

KM 9303.X-01

DN 65–150 PN 16, 25, 40, 63, 100 (160, 250)

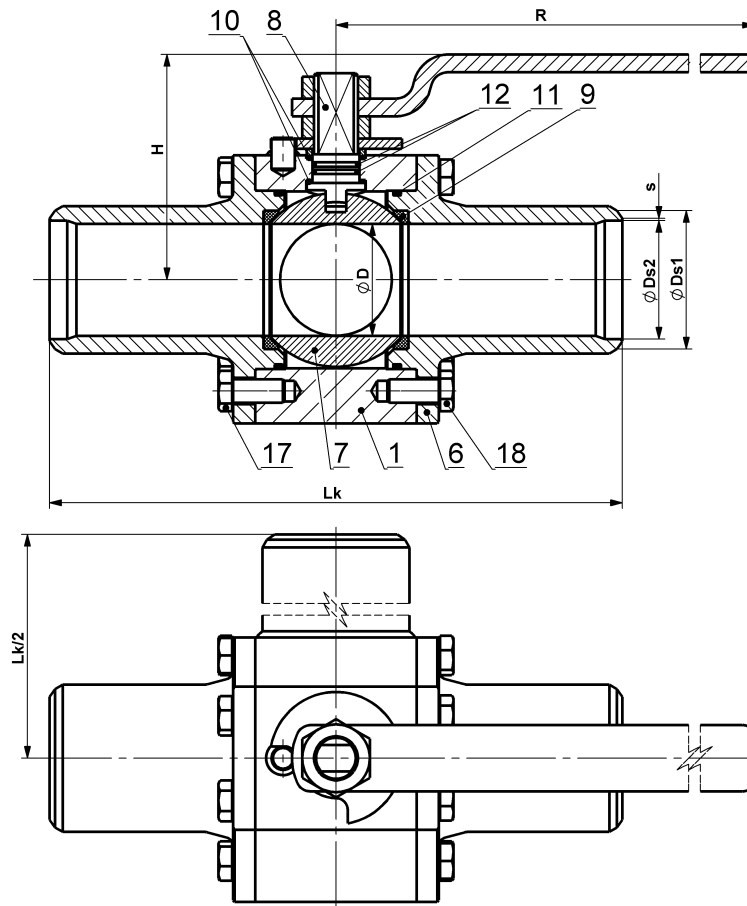

Materials

Type KM 9303.X-01		Material			
		Carbon steel		Stainless steel	
Position	Component	X=1 For common temperatures from -20°C to +200°C	X=5 For low temperatures from -46°C to +200°C	X=3 For temperatures from -50°C to +200°C	X=4 For temperatures from -50°C to +200°C
1	Body	1.0577, S355J2	1.0565, A350 LF2	1.4541, A182 F321	1.4571, A182 F316
2	Socket				
7	Ball	1.4021, ČSN 17 027	1.4541, A182 F321 ČSN 17 027	1.4541, A182 F321	1.4571, A182 F316
8	Stem				
9	Seat	PTFE, PTFE+C, PEEK			
10	Gasket	PTFE+C, PEEK			
11	Sealing	NBR, HNBR, EPDM, FPM, FPM+FEP			
12	Sealing	NBR, HNBR, EPDM, FPM, FPM+FEP			
18	Bolt	8.8, A2-70, A 193 B7	A2-70, A320 L7	A2-70, A193 B8	A2-70, A193 B8

Other materials upon request (P265GH, 1.4306, 1.4462 etc.).

Operating temperature range can be reduced based on selected sealing materials.

Dimensions and weights

PN 16, 25, 40, 63	DN	øD	øDs1	øDs2	s	Trubka / Pipe	Lk	S1	S2	H	R	Hm / W
	10	9,5	18	13	-	17,1×2	270					
	15	14	22	16	-	21,3×2,6	270					
	20	19	27,5	21,5	-	26,9×2,6	270					
	25	25	34	28,5	-	33,7×2,6	270	70	46	102,5	150	3,8
	32	30	43	37	-	42,4×2,6	270					
	40	38	49	42,5	1,5	48,3×2,9	270					
	50	47	61	53,2	1,5	60,3×3,2	300					

PN 16, 25, 40	DN	øD	øDs1	øDs2	s	Trubka / Pipe	Lk	S1	S2	H	R	Hm / W
	65	62	77	69,5	1,5	76,1×3,2	360	-	-			
	80	76	90	81,5	1,5	88,9×4	390	-	-			
	100	95	115	106	1,5	114,3×4	450	-	-			
	125	119	***				525	-	-			
150	150					600	-	-				

PN 63	DN	øD	øDs1	øDs2	s	Trubka / Pipe	Lk	S1	S2	H	R	Hm / W
	65	62	77	68,5	1,5	76,1×3,6	360	-	-			
	80	76	90	80,5	1,5	88,9×4	390	-	-			
	100	95	115	104	1,5	114,3×5	450	-	-			
	125 *	119	***				525	-	-			
150 **	150					600	-	-				

PN 100	DN	øD	øDs1	øDs2	s	Trubka / Pipe	Lk	S1	S2	H	R	Hm / W
	10	9,5	18	13	-	17,1×2	270					
	15	14	22	16	-	21,3×2,6	270					
	20	19	27,5	21,5	-	26,9×2,6	270					
	25	25	34	27,5	1,5	33,7×2,9	270					
	32	30	43	36	1,5	42,4×3,2	270					
	40	38	49	41	1,5	48,3×3,6	270					
	50	47	61	51	1,5	60,3×4,5	300					
	65	62	77	66	1,5	76,1×5	360	-	-			
	80	76	90	77,5	1,5	88,9×5,6	390	-	-			
	100 *	95	115	100	1,5	114,3×7	450	-	-			
	125 **	119	***				525	-	-	-	-	
	150 **	150					600	-	-	-	-	

* = gearbox recommended, ** = with gearbox only, *** = contact our office.

Dimensions in [mm], weights in [kg]. S1 / S2 – Widths across flats for wrench on body / socket.
Dimensions of welding ends according to the dimensional table or customer requirement.

Application

Three-way butt weld end ball valves type KM 9303.X-01 are isolating valves designed either to redirect or to open or close the service fluid flow. They are not designed to be used for throttling or regulating purposes. The scope of application of the ball valves depends directly on their materials and on the properties and temperature of the service fluid. The standard materials are specified in the table of materials. By agreement and based on service conditions, also other materials than those specified in the table may be used.

The ball valves are designated for heating gases (e.g. natural gas, lighting gas, propane-butane mixture, biogas, coke-oven gas), water, steam (not exceeding +150°C), oxygen, and generally for both corrosive and non-corrosive liquids and gases without mechanical impurities. Service temperature range can be from -50°C to +200°C depending on combination of body material and sealing rings. Allowable service pressures are in compliance with the pressure-temperature ratings (graphs B1, S1, S2, S4).

Technical description

Ball valve design meets the requirements of EN 1983. The ball valve is with floating ball. The stem design ensures that the stem can not be ejected from the valve body by pressure of the fluid (anti-blow-out stem), internal components are connected to provide conductivity and resistance to formation of electrostatic discharges (anti-static design).

The ball bore may have the form of either "L" or "T". The position of the ball in the ball valve is shown by the mark on the upper flat of the stem. The ball valve is equipped with two seats for ball sealing, the middle connecting pipe is without a seat. The pressure fluid may be brought to the **middle connection only**, the end connections are outlet connections. The flow possibilities are shown on the schemes, other possibilities can be discussed by phone.

Flow directions

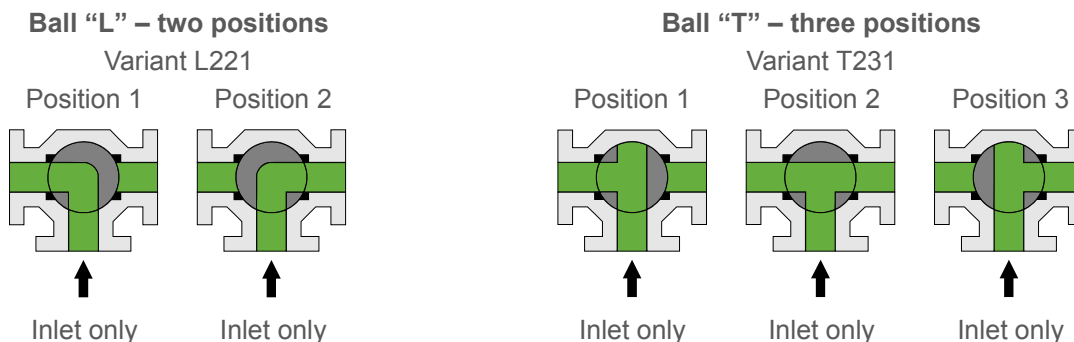

Operation

By lever, gear box with a hand wheel, pneumatic actuator, electric actuator. Dimensions of flanges for actuator installation are in accordance with ISO 5211. The actuator size depends on the maximum service pressure drop through the ball.

The method of operation is indicated by the third digit of the type designation, which is "0" for lever and "3" for actuator (e.g. KM 9331.X-01-01(02)).

Connection to piping

Overall dimensions are shown in the tables of dimensions.

- shapes of welding ends according to EN 17292
- dimension of ball bore according to EN 1983
- end-to-end dimension according to EN 12982

Testing

According to EN 12 266-1 as a standard, i.e. shell strength test P10, P11, seat tightness test P12 (water pressure $1,1 \times PN$ and air pressure 0,6 MPa), leakage rate A – zero leakage. If required by the Customer, additional tests may be performed as well.

Installation, service and maintenance

The ball valves may be installed into the piping in any arbitrary position. They require no special adjustments or maintenance. They are operable at the full pressure drop which equals to PN.

Optional accessories, adjustments and services

- fire-safe design – fire resistance in accordance with EN ISO 10497 (API 607)
- heating jacket – for keeping the fluid liquid
- lockable handle with a padlock – for locking opened / closed position of the valve
- extended stem – e.g. for the reason of insulation of the valve and pipeline
- limit switches
- documentation according to EN 10204 3.1 or 3.2
- special adjustments according to customer requests
- valves for nominal pressure classes PN 160, 250
- execution according to standard NACE MR 0175 or ISO 15156
- execution according to API standards